



<p>Content:</p>  <p>x1</p>  <p>x1</p>	<p>Dimension:</p>  <p>100±0.2 70±0.01</p> <p><small>*Dimensions in mm</small></p>
--	---

EAN: 8719157013932 Item Description: Noxion LED Automatic Dimmer Switch RLC 0-300W 220-240V

EN

Operating Voltage:	220-240V
Frequency:	50Hz
Maximum Load:	300W/VA
Minimum Load:	0W/VA
Dimming Mode:	Auto Leading/Trailing Edge
Extension Option:	Single push-button (No limits)
Dimmable LED Lamps:	RL mode: 0-200W/VA RC mode: 0-300W/VA
Halogen:	10-300W/VA
Incandescent:	10-300W/VA

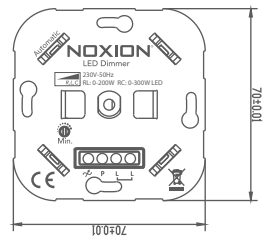
NL

Werkspanning:	220-240V
Frequentie:	50Hz
Maximale belasting:	300 Watt
Minimale belasting:	0 Watt
Dim-methode:	Automatische fase afsnijding/fase aansnijding
Uitbreidingsoptie:	Enkele drukknop (geen grenzen)
Dimbare LED lampen:	Fase aansnijding: 0-200 Watt Fase afsnijding: 0-300 Watt
Halogeen:	10-300 Watt
Gloeilampen:	10-300 Watt

DE

Betriebsspannung:	220-240V
Frequenz:	50Hz
Höchstlast:	300W/VA
Mindestlast:	0W/VA
Dimm-Modus:	Auto Phasenanschnitt/Phasenabschnitt
Optionale Erweiterung:	Einzelner Druckknopf (Keine Begrenzungen)
Dimmbare LED-Lampen:	RL-Modus: 0-200 W/VA RC-Modus: 0-300 W/VA
Halogenlampen:	10-300W/VA
Glühlampen:	10-300W/VA

Wiring Instruction:

One way wiring connection:

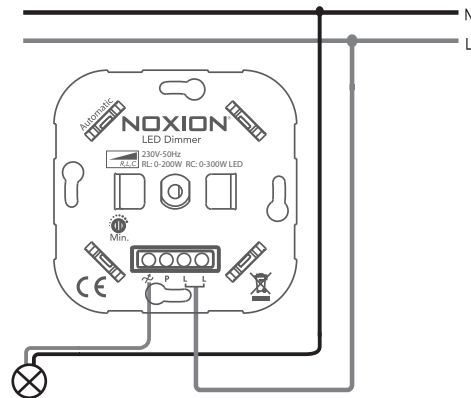

Bedradingsinstructie:

Eéndraadsverbinding:

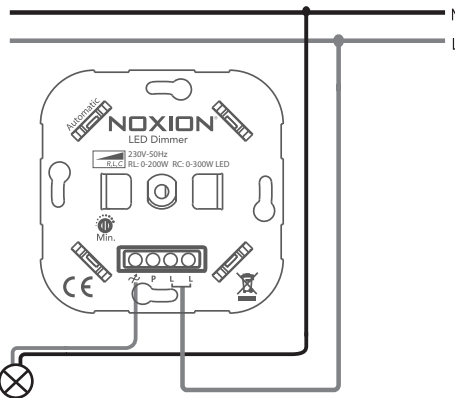

Verdrahtungshinweis:

Einweg-Verdrahtungsverbindung:

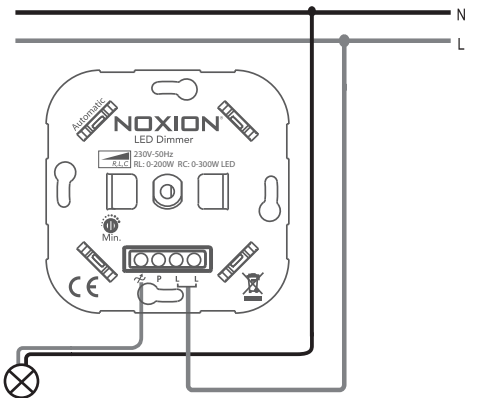

Multiway master+slave wiring connection:

Once connected with a push switch,click the push switch to switch ON/OFF, Press and hold to increase/decrease light intensity.

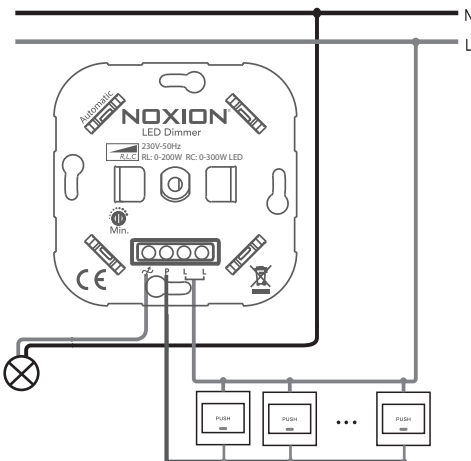

Tweedraadsverbinding:

Eenmaal verbonden met een druschakelaar, klik op de druschakelaar om AAN / UIT te schakelen, Houd ingedrukt om de lichtintensiteit te verhogen / verlagen.

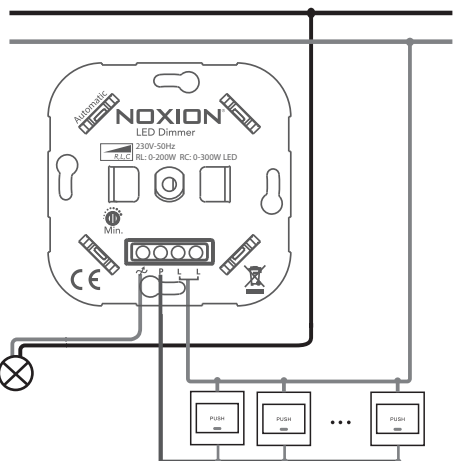

Mehrweg-Master+Slave-Verdrahtungsverbindung:

Sobald die Verbindung mit einem Druckschalter hergestellt ist, klicken Sie auf den Druckschalter, um ihn EIN/AUS zu schalten. Halten Sie die Taste gedrückt, um die Lichtintensität zu erhöhen/verringern.

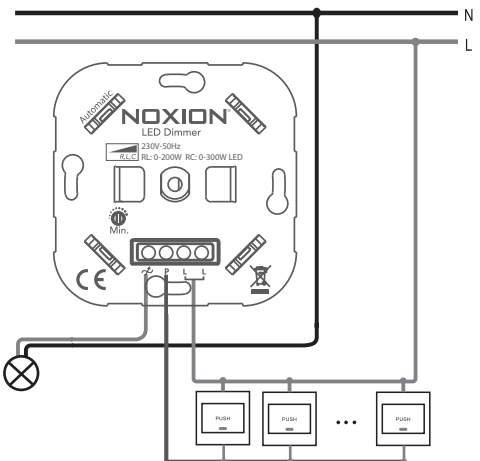

FR

Tension:	220-240V
Fréquence:	50Hz
Charge maximum:	300W/VA
Charge minimum:	0W/VA
Mode de variation:	Coupure de phase avant/arrière
Extension compatible:	Bouton poussoir simple (Aucune limite)
Lampes LED dimmables:	Mode RL: 0-200W/VA Mode RC: 0-300W/VA
Halogène:	10-300W/VA
Incandescent:	10-300W/VA

Instructions pour le câblage :

Branchement simple:

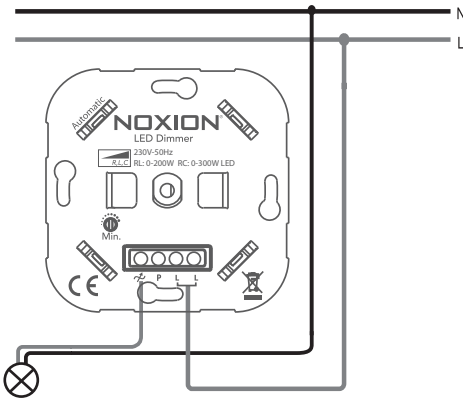

Branchement multiple master+slave:

Une fois connecté à l'interrupteur, appuyez sur le bouton poussoir pour allumer/éteindre la lumière, et restez appuyer pour augmenter/diminuer l'intensité lumineuse.

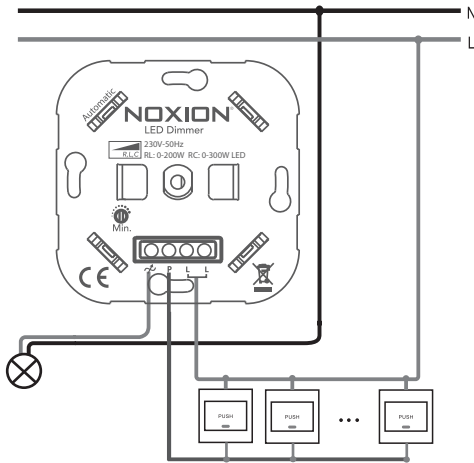

IT

Tensione operativa:	220-240V
Frequenza:	50Hz
Carico massimo:	300W/VA
Carico minimo:	0W/VA
Modalità di dimmeraggio:	Automatica (taglio di fase ascendente/discendente)
Opzione di estensione:	Pulsante singolo (senza limiti)
Lampade LED dimmerabili:	Modalità RL: 0-200W/VA Modalità RC: 0-300W/VA
Tecnologia alogena:	10-300W/VA
Incandescenza:	10-300W/VA

Istruzioni di cablaggio:

Collegamento del cablaggio unidirezionale:

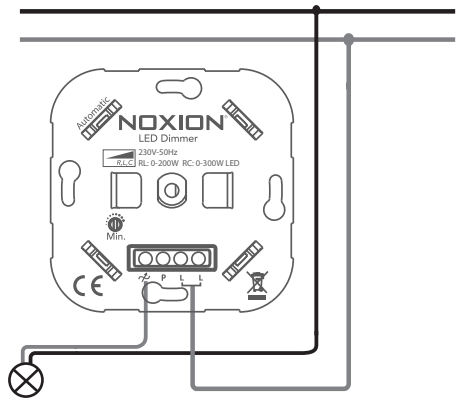

Collegamento cablaggio master e slave a più vie:

Una volta collegato con un interruttore a pulsante, premere l'interruttore a pulsante per accendere o spegnere. Tenere premuto per aumentare o ridurre la luminosità.

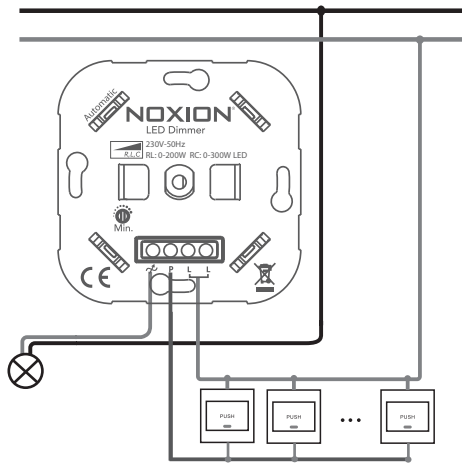

ES

Voltaje:	220-240V
Frecuencia:	50Hz
Carga máxima:	300W/VA
Carga mínima:	0W/VA
Modo de atenuación:	Automático (atenuación de fase inicial/final)
Opción de extensión:	Solo un botón (sin límites)
Lámparas LED regulables:	Modo RL: 0-200W/VA Modo RC: 0-300W/VA
Tecnología halógena:	10-300W / VA
Incandescente:	10-300W / VA

Instrucciones de cableado:

Conexión de cableado unidireccional:

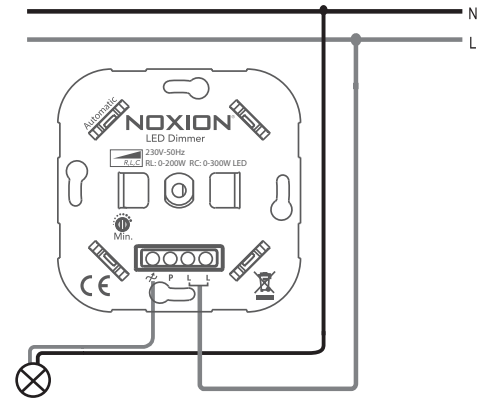

Conexión de cableado maestro y esclavo multidireccional:

Una vez conectado con un interruptor de botón, presione el interruptor de botón para encenderlo o apagarlo. Mantenga presionado para aumentar o disminuir el brillo.

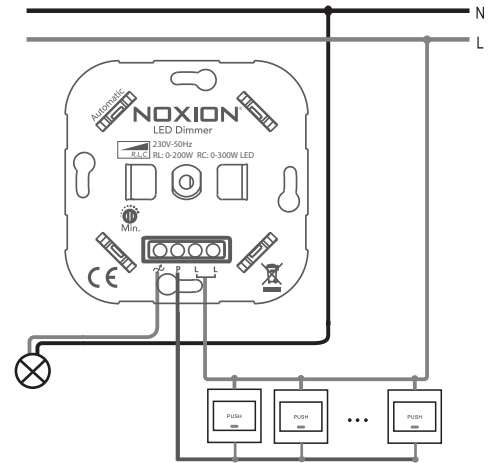

EN The luminaire shall be installed and maintained by a qualified electrician, in accordance with the national regulations in each country. The luminaire contains no replaceable parts. In case of the luminaire is damaged, it shall be exclusively replaced by the manufacturer or authorized dealer. Keep the operating manual for later use. The manufacturer is not responsible for the incorrect use and assembly of this product.
NL De armatuur dient te worden geïnstalleerd en onderhouden door een erkend installateur, in overeenstemming met de nationale regelgeving in het betreffende land. De armatuur bevat geen vervangbare onderdelen. Indien de armatuur is beschadigd dient deze enkel te worden vervangen door de fabrikant of door een erkende dealer. Bewaar de handleiding voor later gebruik. De fabrikant is niet verantwoordelijk voor onjuist gebruik en/of installatie van dit product. **DE** Die Leuchte muss von einem qualifizierten Elektriker gemäß den nationalen Vorschriften in jedem Land installiert und gewartet werden. Die Leuchte enthält keine austauschbaren Teile. Falls die Leuchte beschädigt ist, wird sie ausschließlich durch den Hersteller oder den autorisierten Händler ersetzt. Bewahren Sie die Bedienungsanleitung für spätere Verwendung auf. Der Hersteller ist nicht verantwortlich für die unsachgemäße Verwendung und Montage dieses Produktes. **FR** Le luminaire doit être installé et entretenu par un électricien qualifié, conformément à la réglementation nationale de chaque pays. Le luminaire ne contient pas de pièces remplaçables. Dans le cas où le luminaire est endommagé, il doit être remplacé exclusivement par le fabricant ou le revendeur agréé. Conservez le mode d'emploi pour une utilisation ultérieure. Le fabricant n'est pas responsable de l'utilisation et du montage incorrects de ce produit. **IT** L'apparecchio deve essere installato e mantenuto da un elettricista qualificato seguendo le normative nazionali di riferimento. L'apparecchio non contiene parti sostituibili. In caso di rottura sarà sostituito esclusivamente dal produttore o da un rivenditore autorizzato. Conservate il manuale di installazione per eventuali utilizzi successivi. Il produttore non è responsabile per l'utilizzo ed il montaggio non corretto di tale apparecchio. **ES** La luminaria debe de ser instalada y mantenida por un electricista cualificado, siguiendo las regulaciones nacionales de cada país. La luminaria contiene partes no reemplazables. En el caso de que la luminaria sea dañada, deberá ser reemplazada exclusivamente por el fabricante o distribuidor autorizado. Guarde el manual para usos posteriores. El fabricante no es responsable por el uso e instalación incorrecta de este producto.